

Service Schematics

NOKIA 7230

RM-598/RM-604



IMPORTANT

This document is intended for use by authorized Nokia service centers only. Please use the document together with other documents such as the Service Manual and Service Bulletins.

Version information

While every effort has been made to ensure that the document is accurate, some errors may exist. Please always check for the latest published version for this document.

If you find any errors in the document please send email to:
TrainingAndVendorDevelopment@nokia.com

Version history

1.0	First Approved version
2.0	First published version. General update based on quality review

Table of Contents

Front page	1
RAPS, HS USB, Sensors, Memory, UI	2
GAZ00, Audio, MMC, SIM, Battery	3
Keyboard I/F, Keyboard Backlighting	4
BTHFM	5
RF part	6
Component Finder Top	7
Component Finder Bottom	8

Copyright © Nokia

This material, including documentation and any related computer programs is protected by copyright, controlled by Nokia. All rights are reserved. Copying, including reproducing, modifying, storing, adapting or translating any or all of this material requires the prior written consent of Nokia. This material also contains company confidential information, which may not be disclosed to others without the prior written consent of Nokia.

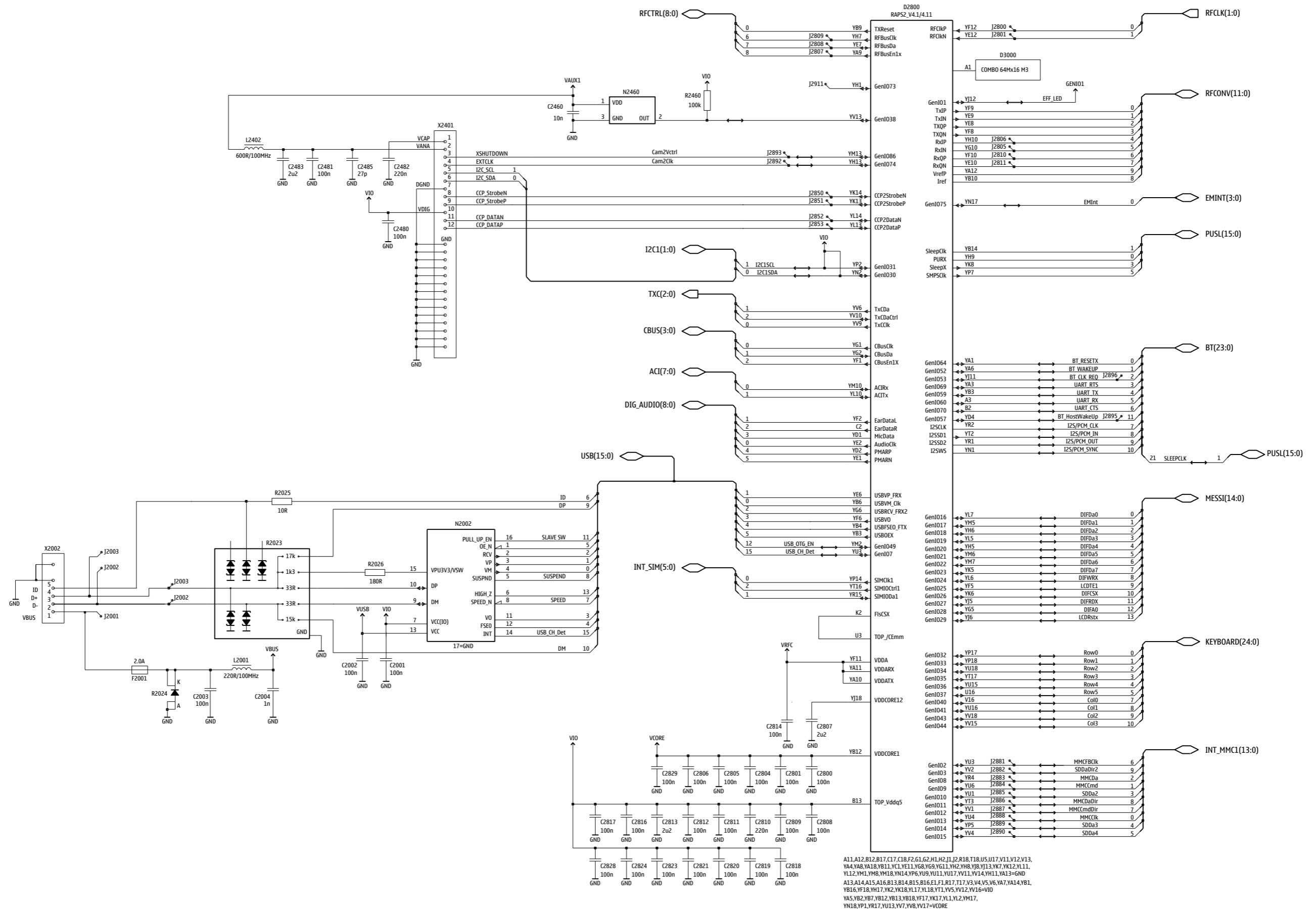

A11,A12,B12,B17,C17,C18,F2,G1,G2,H1,H2,J1,J2,R18,T18,U5,U17,V11,V12,V13,
 YA4,YA8,YA18,YB11,YC1,YE11,YG8,YG9,YG11,YH2,YH8,YJ13,YK7,YK12,YL11,
 YL12,YM1,YM8,YM18,YN14,YP6,YU9,YU11,YU17,YV11,YV14,YH11,YA13=GND
 A13,A14,A15,A16,B13,B14,B15,B16,E1,F1,R17,T17,V3,V4,V5,V6,YA7,YA14,YB1,
 YB16,YF18,YH17,YK2,YK18,YL17,YL18,YT1,YV5,YV12,YV16=VIO
 YA5,YB2,YB7,YB12,YB13,YB18,YF17,YK17,YL1,YL2,YM17,
 YN18,YP1,YR17,YU13,YV7,YV8,YV17=VCORE

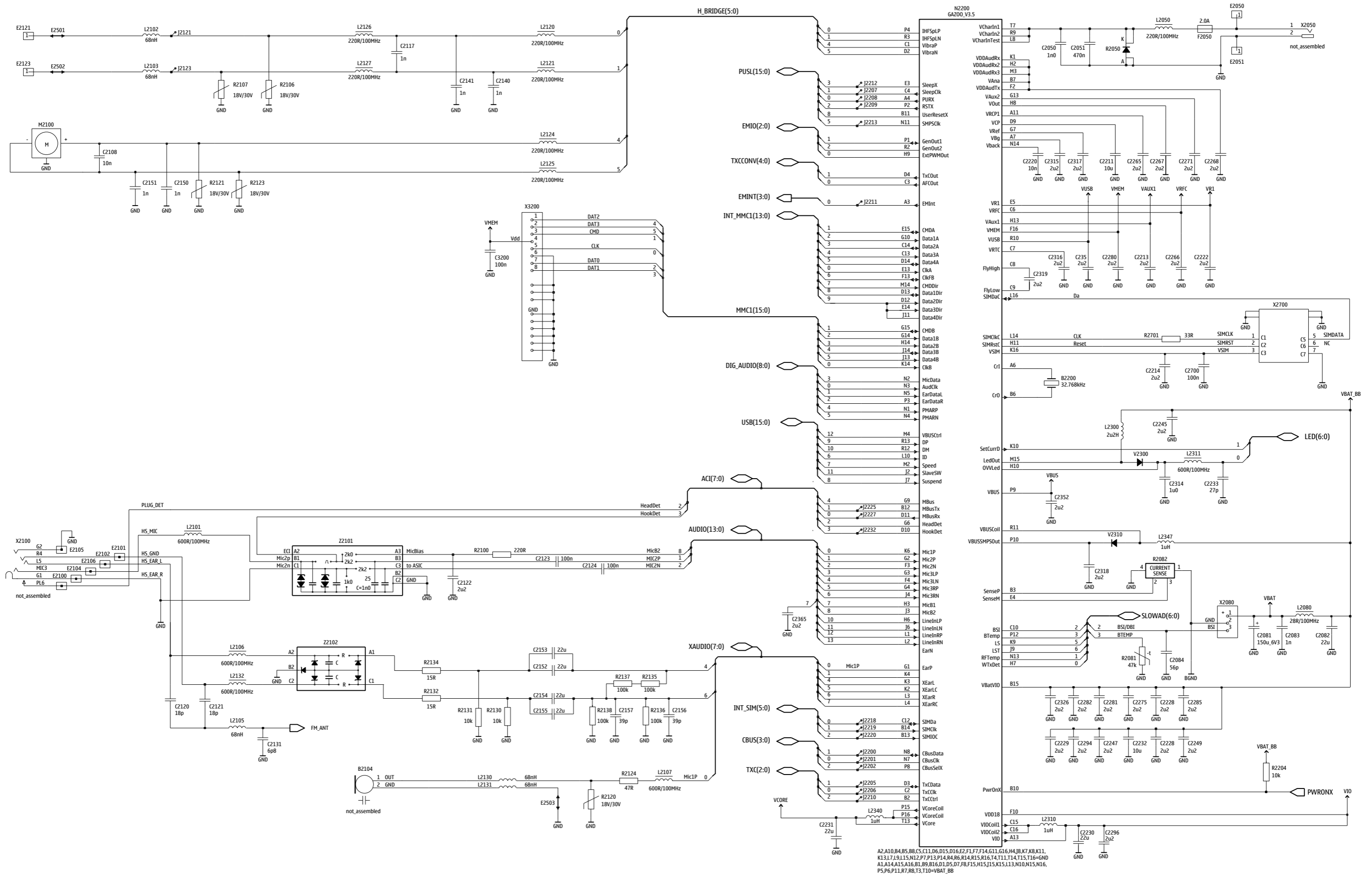

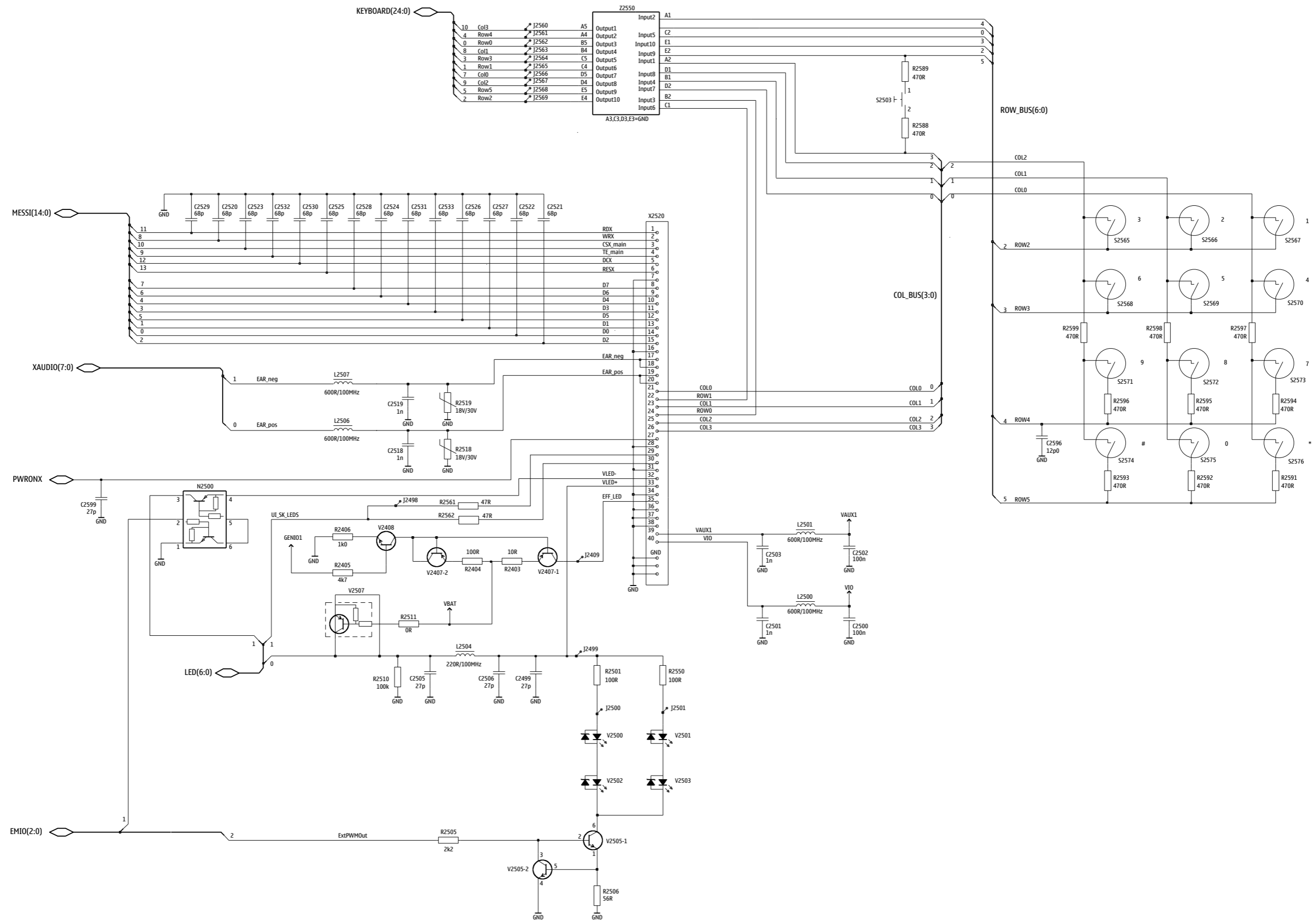

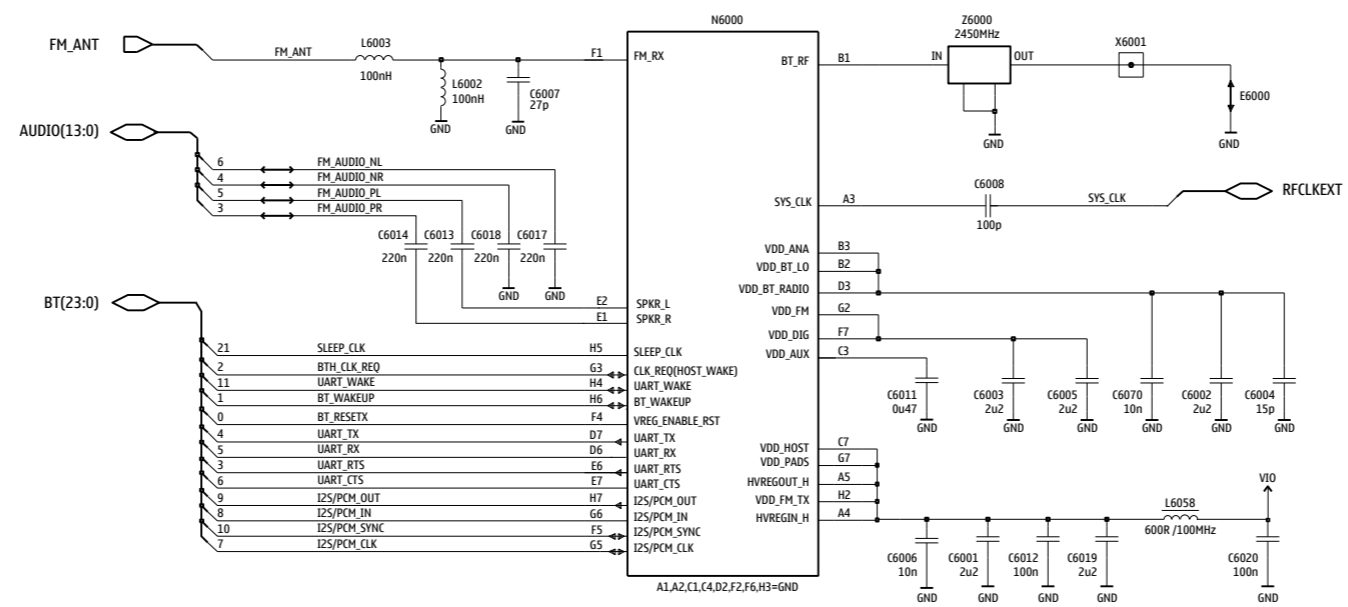

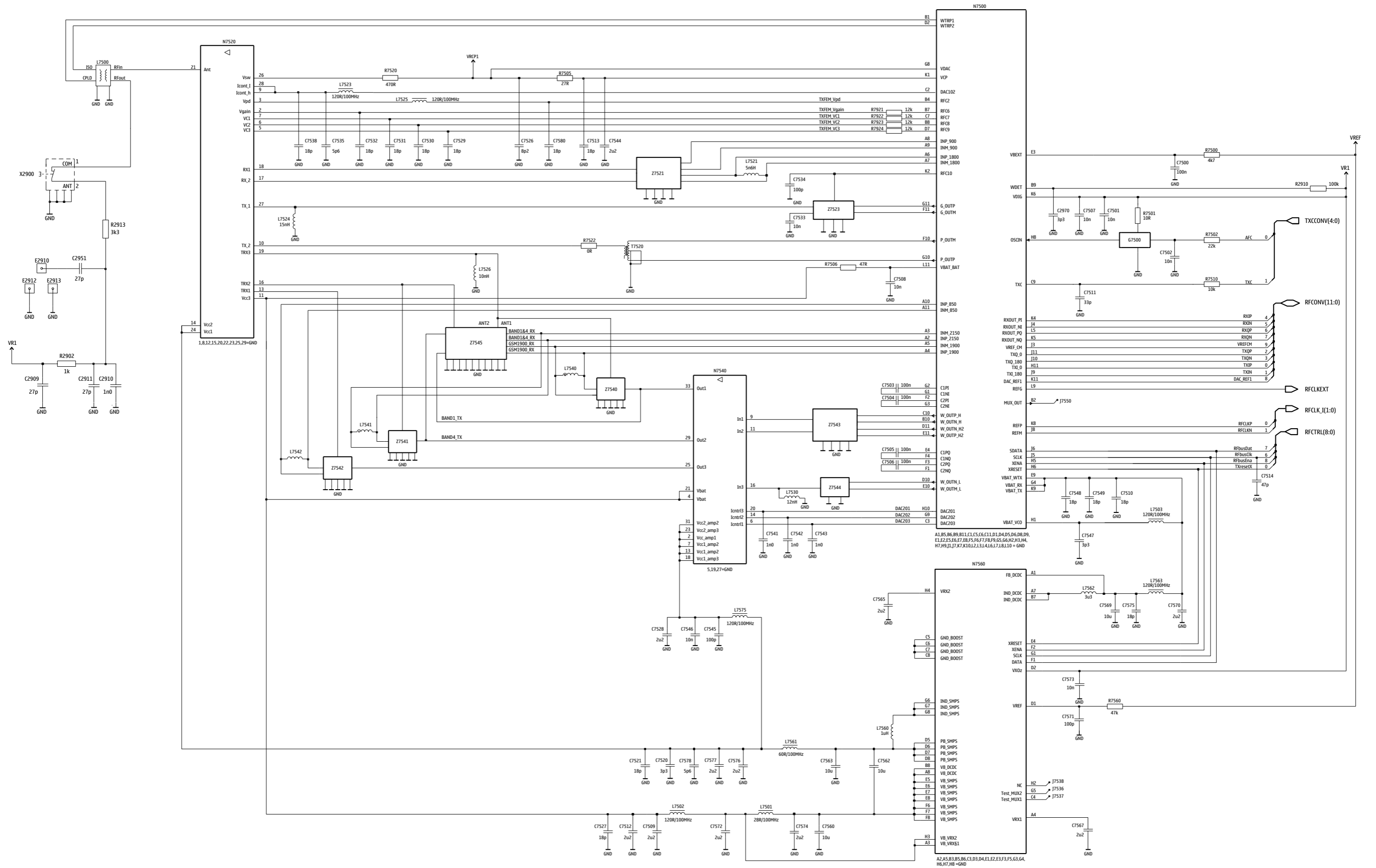

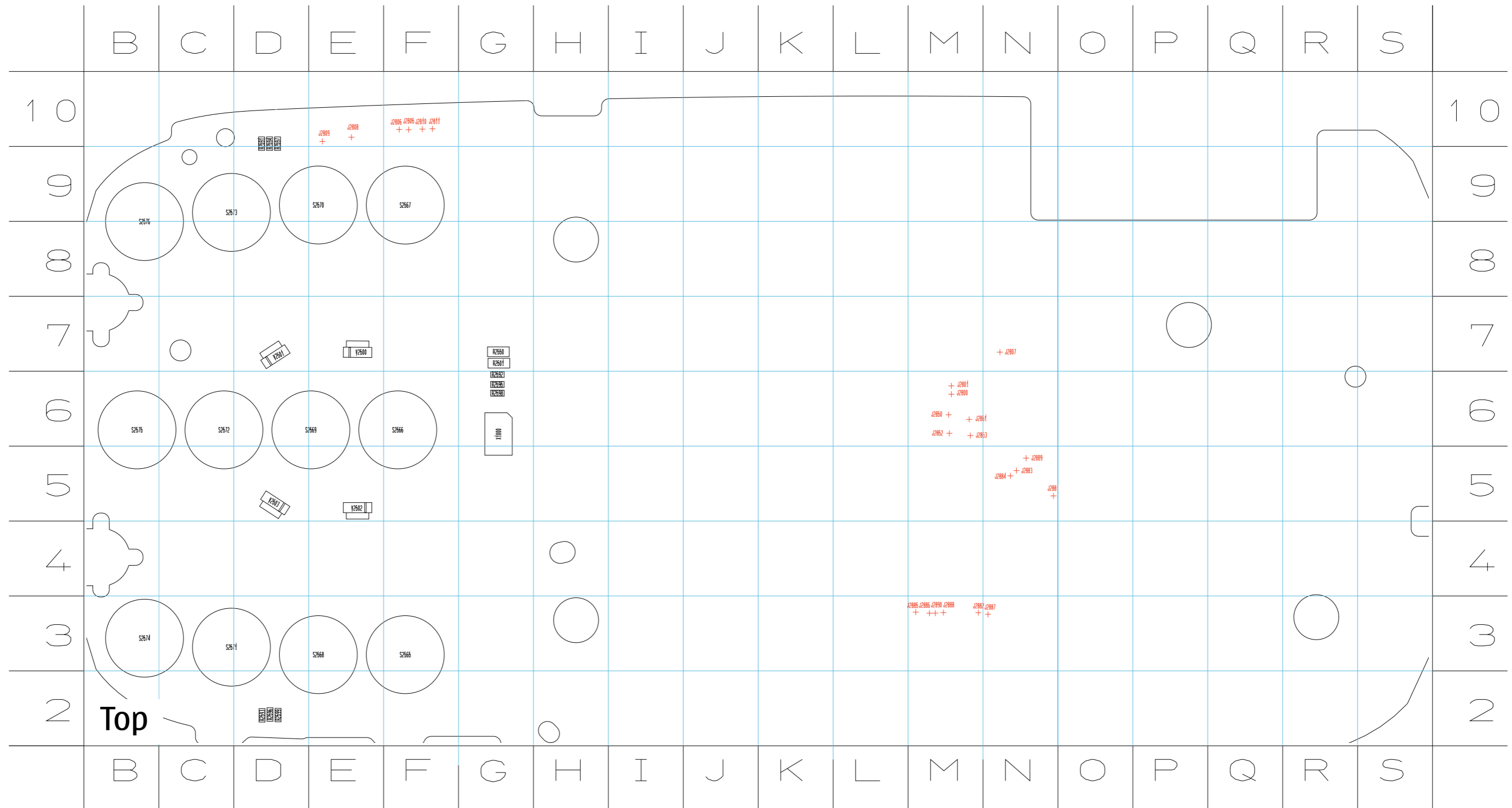

R	R2593	D2	R2598	G6	V2502	E5
R2501	G7	R2594	D10	R2599	D2	V2503
R2550	G7	R2595	G6	V	X	
R2591	D10	R2596	D2	V2500	E7	X1000
R2592	G6	R2597	D10	V2501	D7	

